



What VLT® is all about

VLT® drives increase productivity

Market-leading Danfoss will help you stay ahead in your field.

For more than 30 years now, reliable and efficient automation systems from Danfoss Drives have increased companies' productivity, saved energy and improved comfort levels. At the heart of these achievements are our top brands VLT® electronic motor controls.

While being number one in Europe and, among dedicated drives providers, the leading supplier globally, Danfoss Drives is still gaining ground.





Danfoss Drives stands by you – 24/7 – around the globe

2000 drives specialists are at your service in 120 countries, ready to support you.

The international headquarters in Graasten, Denmark, are home to advanced research and development facilities along with global management. This is also where one of the Danfoss high-tech production plants is situated. Other main factories are located in USA, Germany and in China.

Danfoss Drives is part of the Danfoss Group – a global company with net sales of about 2.2 billion EUR employing approx. 18,200 people worldwide.

Since 1933 Danfoss has mastered advanced technology and provided their customers with competitive advantages and increased productivity.







Dedicated to Drives Solutions

When drives are the issue, ask an expert's opinion. Danfoss Drives has focused on providing solely drives and accessories for 30 years and accumulated a deep understanding of technologies, applications and customer needs in this narrow area.

Danfoss Drives introduced the world's first mass-produced frequency converter in 1968 – named VLT® – and has since been breaking ground within technology applicable to the industries.



Mass customisation

To meet demands for both competitive and customised solutions Danfoss Drives introduced masscustomisation.

Out of a limited number of components and options you can order your special combination from millions of variations and solutions – have it assembled, tested and delivered anywhere in the world within 48 hours.



Team up with Experts

It takes experts to turn original ideas into reliable and cost-effective solutions. Danfoss Drives only produces drive solutions.



This position enable us to focus on business areas such as manufacturing, heating and ventilation, material handling, chemical, water and wastewater, refrigeration, textile, food and beverage from a drives solutions angle.

Danfoss vouch for all vital elements

Vital elements in drive solutions are customer focused design, software, power electronics, reliable assembly, careful testing, dedication of solutions, near-by backup.





Unlike several competitors, Danfoss Drives performs all these tasks in-house in order to exercise full control of quality and service.

Local sales companies – worldwide

Danfoss Drives sales and service organization covers all continents.

Drives experts with expert knowledge of both business and applications – and local culture and language – are on call around the world around the clock.

Dedicated products

By knowing their customers' business, Danfoss develops business dedicated drive solutions for e.g. heating and ventilation, water and waste water applications, food and beverage industry. Smooth and dirt repelling, tightly enclosed drives solutions for decentral mounting in food manufacturing is an example.

Protecting the environment

Wherever we operate, consideration for the environment and the well-being of people is a top priority. By minimising the consumption of energy and raw materials and by utilising all resources effectively, pollution is reduced and negative environmental impacts eliminated.

Danfoss Drives is in all product series implementing the EU Directive concerning Hazardous Substances in Electrical and Electrical Equipment (RoHS).



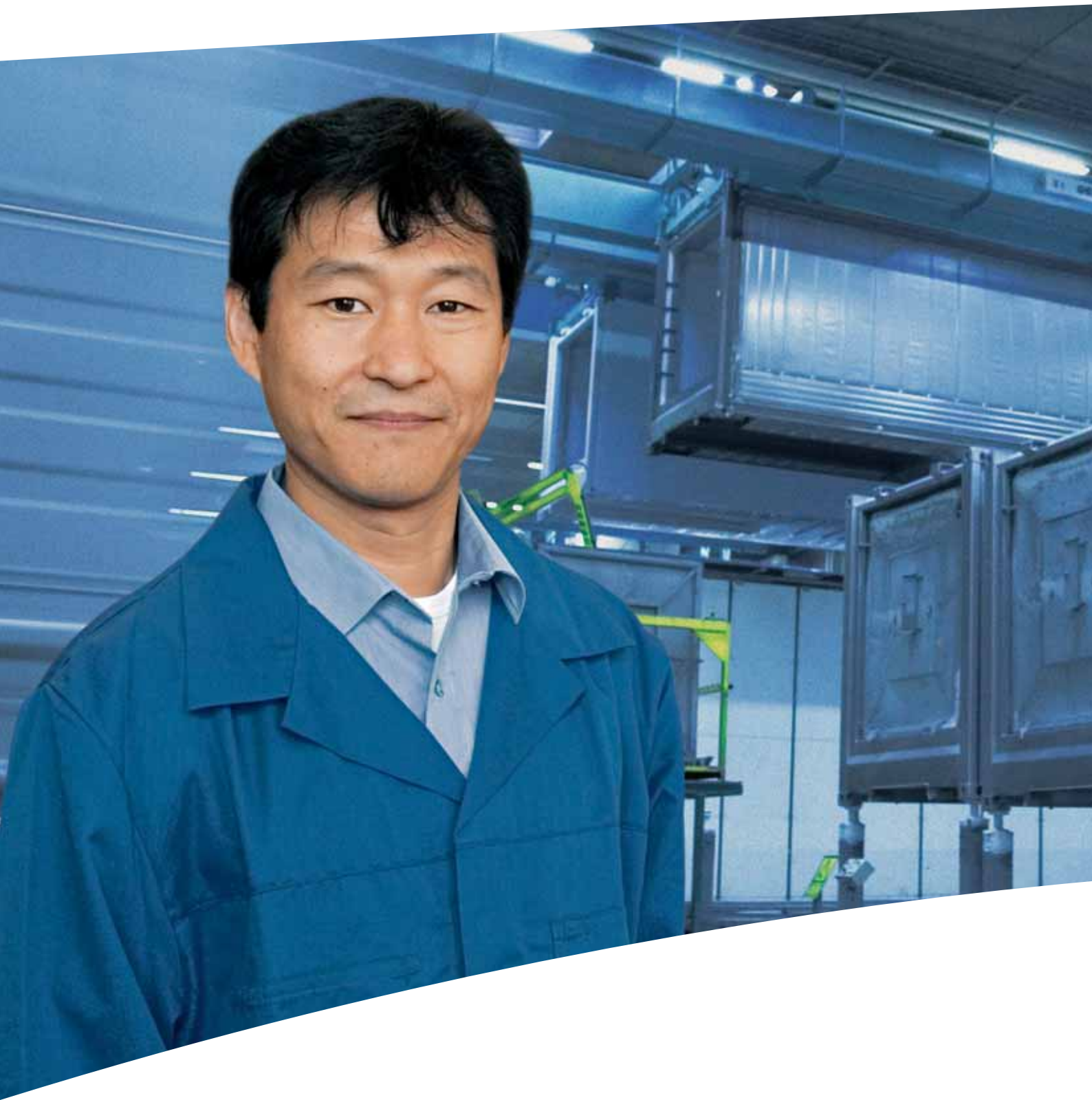



Dependable people – dependable solutions

Danfoss Drives shares the common Danfoss core values:

- Our business is trust
- A very safe and reliable choice
- Passionate about technology
- Global culture, local representation
- Environmentally and socially responsible.

The entire business organisation is built on an upright approach to customers and applications, vouching for every step from design, manufacturing, sales and delivery to commissioning and after sales services.

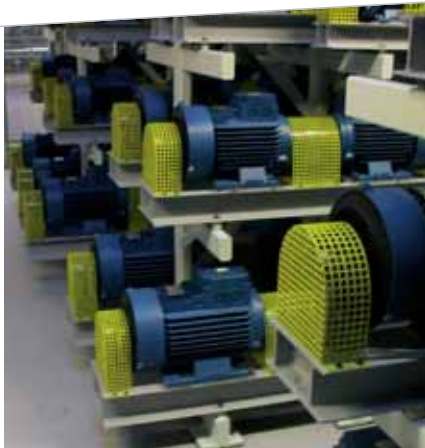

Strong relationships with employees, partners, and customers are vital for the company – as are relationships with the environment.

From initial design to final assembly, Danfoss Drives uses advanced IT-systems along with sophisticated production and testing techniques to manufacture reliable drives solutions. Solutions are designed to meet your specifications, perform perfectly at all times and withstand the everyday stresses of the environment.



Saves an atomic plant each year

Every time a VLT® drive is installed on a motor, it saves energy. This is the case especially in HVAC applications. The present production of VLT® drives over a year will save – as long as they function – as much energy as an average atomic power plant. It takes



1.5 year of VLT® production to replace Ignalina Nuclear Power Plant in Lithuania – the World's largest atomic power plant.

One-Stop-Supplier

Being a one-stop-supplier enables Danfoss Drives to take responsibility for the entire process from initial sale to installation, commissioning and user training.

Tailored After Sales Services

Danfoss Drives tailors after sales services to meet customer's specific needs. The level of service is determined by individual cost-benefit analysis assuring sufficient back-up without services exceeding the customers' needs.



Dependable solutions within 48 hours

From anywhere in the world, local sales companies specify required features directly into Danfoss Drives production management system. The completely automated supply chain hereafter provides bits and pieces for robots to assemble the drives. Before enclosures are mounted, drives are tested visually, electronically and physically – under full scale conditions. No stock will be short, no version sold out.

Safe stop

Built-in safety features allow for one wire safety installations using VLT® drives.

Products Self Protect

VLT® drives monitor the performance of applications as well as their own. VLT® drives take action to live through periods of overload without disturbing the operator. Early warnings alert the operator allowing time to prevent production stop. Eventually the drives will stop, unharmed and ready to start up again. Logs of vital parameters and alarms allow for preventive troubleshooting.

Reliable operation under extreme conditions

In the case of fire, VLT® drives are able to maintain a higher level of air pressure in stair-wells than in other parts of the building, thus ensuring that fire escapes remain free of

smoke. In Fire Override Mode the drive will not stop because of non-relevant control signals, warnings or alarms. It will continue reliable operation until conditions destroy it.

Compatible – backwards and forwards

New VLT® products and solutions are designed to be compatible with previous – and upcoming – generations. VLT® drives will integrate seamlessly with existing applications and drives solutions, whether they comprise third-party equipment, VLT® drives or a combination of both. And drives of today are designed to easily adapt to future technologies.







It takes innovation to stay ahead

Customers are actively involved in the development and design of VLT® drives to identify fields for improvements and advantages. Through dialogue, studies and field tests future demands on drives technology and performance are explored.

Results are user-friendly and reliable running hand in hand with useful new features and sophisticated technology. Latest technological advances are engaged as they are made.

What brings a company ahead in its field is the sum of its advantages compared to competitors.



Hunting better solutions

Product development is given highest priority within Danfoss Drives. No company matches the technology and application knowhow of the Danfoss staff. Unique technology and highly adaptable solutions are designed to fulfil everchanging needs of customers.

Future means modular

Having identified basic drive architecture – components and their interfaces – Danfoss develops and produces for many different drive series when developing and producing one component. The latest series comes in millions of hardware configurations – all built from limited series of different components, making each drive highly customised – and produced overnight. You get a tailored drive for the price of a mass produced standard drive.



design award
winner
2004

The new VLT® series local control panel (LCP) was given the international iF design award in 2004. The panel was chosen from a total of 1,003 entries from 34 countries in the category "interface in communication".



Danfoss Drives received the Frost & Sullivan Award for Product Innovation 2006 for the unique VLT® AutomationDrive series.



Common Platforms

Elements are based on common technology platforms and shared interactions protocols. New components can therefore be developed in parallel. Likewise, production can take place at the same time in our different factories around the world.

Award-Winning Design

Persistency pays off. The customer focused design process leading to the new user interface of VLT® HVAC Drive and VLT® AutomationDrive have won awards. The iF Design Award – one of the most important international design awards in the world – was presented to the local control panel in 2004. The involvement of users, the structure of features and the overall design, look and feel of the control panel made it stand out in front of a total of 1,003 entries in the competition.

Customized Manuals

While a tailored drive is automatically assembled, computers gather relevant text and illustrations for this specific drive – in the relevant language – selected and updated to match the individual specifications of the drive. As only customized manuals are printed and immediately packed and delivered, no stocks of – possibly outdated – manuals burden the price of the drives.

Configure on the Internet

At any hour of the day, you can buy and configure a VLT® frequency converter using the Drive Configurator at www.danfoss.com/drives. The configurator is an intelligent web catalogue fully integrated with Danfoss Drives' production management system.

Smarter new generations

Automation evolves constantly and VLT® solutions with it. Automatic Motor Adaption, Quick Set-Up menus, On-board manuals in 27 languages, built-in PLC-functions and SBA dedicated features, and overall flexibility makes for improved usability. Ongoing improvements in design, logistics and organisation makes for faster, cost effective manufacturing and better support.

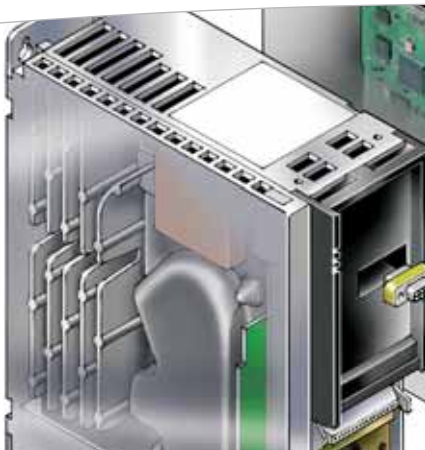

Modular principles in development and production means that innovations have shorter time to market.

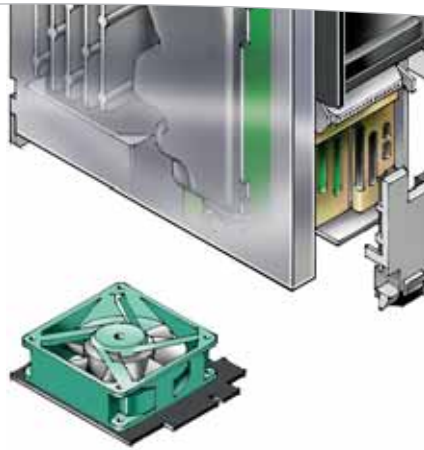

Flexible and vulnerable connections are history in the new VLT® drive series. VLT® drives are clicked and plugged together for reduced costs and improved stability.

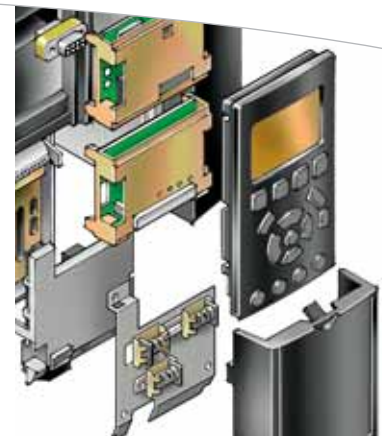

Modularity means flexibility. Updating and renewal of your drive is basically a matter of "plug and drive".



Automation VLT®

Hand On

Off

Auto On

Res

Alarm

Warn.

On



Advanced Technology – Easy to Use

Frequency converters – allowing standard AC motors to vary speed and torque in a very controlled way – are the core of our business.

They make efficient automation systems, major energy savings and improved comfort levels possible in a cost effective way. The performance ranges from accurate control of

torque, speed and acceleration to advanced servo performance, synchronisation and positioning features and the power ranges up to 1.2 MW.

VLT® Frequency Converters

Frequency converters control speed, torque, and the overall performance of AC motors by controlling the power input.

Mastering this technology to optimise operation of any motor powered application is the core of our business.



The VLT® Drive Motor

The VLT® Drive Motor combines the benefits from a frequency converter with the power of a high efficiency motor – all in one compact package with a number of built-in features.

Accessories

Danfoss Drives provides accessories such as harmonic filters, brake resistors, mounting kits, and bus interfaces e.g. required for certain applications.





Software

VLT® electronic motor controls are designed to – via busses – communicate with other control devices, local control panels and computers. Special VLT® software solutions are available to plan, overview and commission even large systems of drives. The VLT® Set-up Software MCT 10 exploits the full PC functionality to provide the general overview and control of even highly complex systems.

Decentral Solutions

VLT® Decentral drives can be mounted on or near motors. This allows for design flexibility, downsizes control cabinets and lets heat disperse in plant environments. Looping of mains and control cables – and very short motor cables – means savings on wiring and elimination of EMC problems.

Decentral drives are designed to withstand harsh environments and frequent wash downs having tight enclosures with smooth and durable surfaces.

Soft Start and Stop

Starts and stops wear hard on machines and products. Power consumption, strains and pressures peak as materials and products are accelerated. To extend product life and to reduce power consumption, VLT® Soft Starters provide smooth motor operation with acceleration and deceleration.

VLT® soft starters are integrated parts of the overall plant control – together with central and decentral frequency converters.





Protects environment

VLT® products are manufactured with respect for environment, safety and wellbeing.

All activities are planned and performed taking into account the individual employee, the work environment and the external environment. Production takes place with a minimum of noise, smoke or other pollution and environmentally safe disposal of the products is assured.

UN Global Compact

Danfoss has signed the UN Global Compact on social and environmental responsibility and our companies act responsibly towards local societies.

EU Directives

All factories are certified according to ISO 14001 standard. All products fulfil the EU Directives for General Product Safety and the Machinery directive. Danfoss Drives is in all product series implementing the EU Directive concerning Hazardous Substances in Electrical and Electrical Equipment (RoHS) and is designing all new product series according to the EU Directive on Waste Electrical and Electronic Equipment (WEEE).

Products impact

One year's production of VLT® drives will save energy equivalent to the energy production of a power plant. Better process control at the same time improves product quality and reduces waste and wear on equipment.

What VLT® is all about

Danfoss Drives is the world leader among dedicated drives providers – and still gaining market share.

Dedicated to drives

Dedication has been a key word since 1968, when Danfoss introduced the world's first mass produced variable speed drive for AC motors – and named it VLT®.

Two thousand employees develop, manufacture, sell and service drives and softstarters in more than one hundred countries, focused only on drives and softstarters.

Intelligent and innovative

Developers at Danfoss Drives have fully adopted modular principles in development as well as design, production and configuration.

Tomorrow's features are developed in parallel using dedicated technology platforms. This allows the development of all elements to take place in parallel, at the same time reducing time to market and ensuring that customers always enjoy the benefits of the latest features.

Rely on the experts

We take responsibility for every element in our products. The fact that we develop and produce our own features, hardware, software, power modules, printed circuit boards, and accessories is your guarantee for reliable products.

Local backup – globally

VLT® motor controllers are operating in applications all over the world and Danfoss Drives' experts located in more than 100 countries are ready to support our customers with application advice and service wherever they may be.

Danfoss Drives experts don't stop until the customer's drive challenges are solved.

